

THIS DRAWING IS UNPUBLISHED. RELEASED FOR PUBLICATION, 19
 © COPYRIGHT 19 BY AMP INCORPORATED, HARRISBURG, PA. ALL INTERNATIONAL RIGHTS RESERVED. AMP PRODUCTS MAY BE COVERED BY U.S. AND FOREIGN PATENTS AND/OR PATENTS PENDING.

LOC	DIST	P	F	ZONE	LTR	DESCRIPTION	DATE	APPROVED
AF	50				J	OBSOLETE -3 PER 0710-0273-96	15/JUL/96	PF/GY

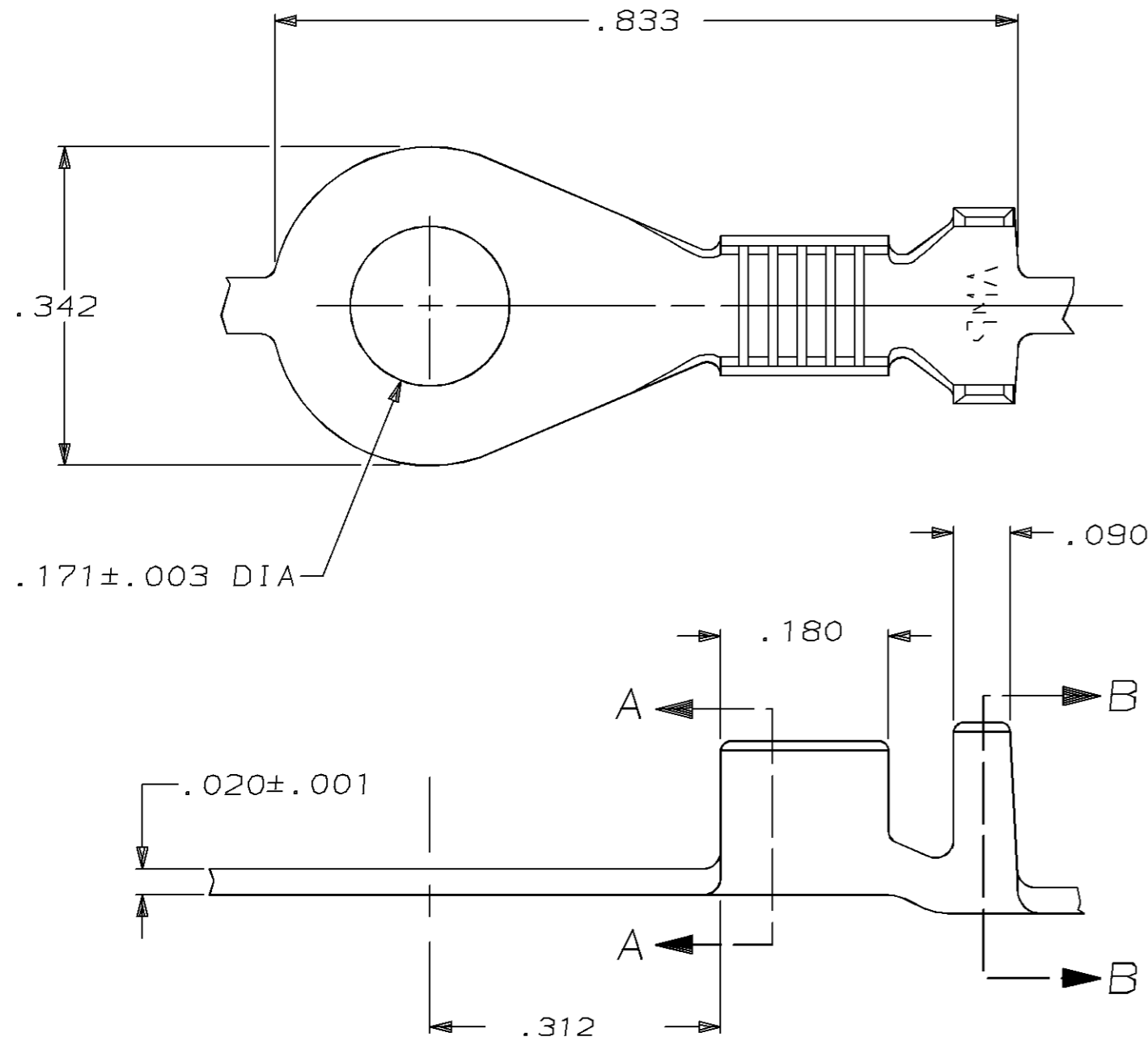

△ 1 TIN PL .000200 MIN PER MIL-T-10727 OVER
 COPPER PL .000100 MIN PER MIL-C-14550

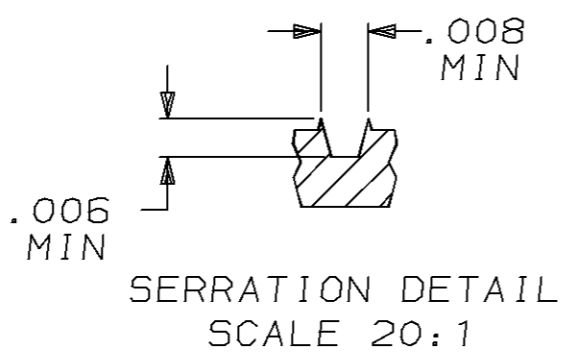
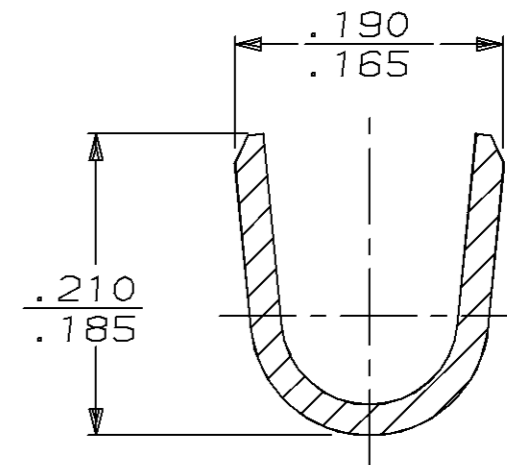
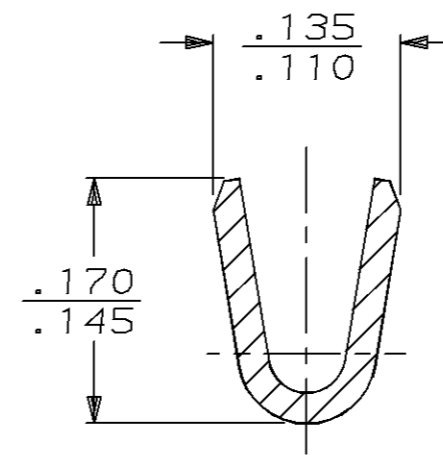

OBSOLETE	△	.100-.140	18-14	60320-3
	TIN PL	.100-.140	18-14	60320-2
		.100-.140	18-14	60320-1

UNLESS OTHERWISE SPECIFIED DIMENSIONS ARE IN INCHES TOLERANCES ON:		DR P FORTNEY 6/4/87	AMP INCORPORATED Harrisburg, Pa. 17105	
2 PL DEC ± -		CHK G YETTER 1/6/88		
3 PL DEC ± .015		APPD RP FRANTZ 1/7/88	NAME	
ANGLES ± -		APPD TL SHUTTER 1/12/88	RING, AMPLIVAR	
MATERIAL	T1 BRASS	PRODUCT SPEC	SIZE	B
FINISH	SEE TABLE	APPLICATION SPEC	FSCM NO	00779
		WEIGHT	DRAWING NO	60320
			SCALE	6:1
			SHEET	1 OF 1